

FUJIFILM



NEW

FUJIFILM COMPUTED RADIOGRAPHY

DYNAMIXTM
HR / Series 5

Seeing the past, present, or future? See it all with the high resolution images of Dynamix.

FCR's proprietary image processing technology provides you with enhanced capacity to confirm even the minute interior structures of inspection objects with its new features.

Proprietary Imaging Plate (IP) FCR Systems

Fujifilm, the absolute pioneer in digitized medical X-ray imaging, advanced into the industrial inspection field in 1989. Through the building up of proprietary technologies such as evidenced by our imaging plate (IP), a total alternative to X-ray film, we have realized evermore efficiency and quality of inspection work with our high clarity images now through Dynamix — an X-ray inspection system product lineup that provides totally reduced shooting time, eliminates the use of chemicals in developing, and the convenience of reusable IPs where stored data can be erased. All to name a few as the alternative solution to conventional X-ray filming.

DISTINCT

High resolution

DIGITAL

Highly technological

ECOLOGICAL

Environment friendly

Dynamic Range

Wide dynamic range resulting in wide allowance of X-ray exposure value

Easy Image Processing

Adjust images to optimal state according to inspection purpose

Minimized X-ray Exposure

Maximized image quality with minimum exposure compared to X-ray film

High Resolution Reading

High precision 50µm reading (Dynamix HR)

Exposure Data Recognizer

Automatic image optimization with "EDR"

Image Transmission

Transmit and share digital images with PCs

Storage Media Versatility

Allows compact storage of high quality images and quick data retrieval

Totally Dry

No more darkroom, processing chemicals or water

Totally Reusable

Images are erasable with IP, providing the best economical solution

High Resolution Monitor

High resolution and high contrast

IP Sizes

35.4 cm × 43.0 cm

Easily capture even large objects with a maximum size of 35.4 × 43.0 cm

High precision 12-bit 50µm reading allows inspection of minute image details.

50µm 100µm



From X-ray exposure to data management, the digitalized workflow brings high productivity.

Having combined a small footprint with high-performance, you can obtain high precision 50µm reading with simple operations.

IP Reader Units (reader/console)

Dynamix HR (50µm/100µm)
Dynamix Series 5 (100µm)

- FCR – high resolution image reading technology with a proven track record.
- Optimal image consistency with EDR (Exposure Data Recognizer).
- High precision 50µm reading.
 - HR unit only and requires 50µm IP (UR-1) with special cassette (UR)
 - cassette adaptor required for 24 x 30 cm IPs
- High speed reading of 72 IPs an hour (25.2 x 30.3 cm IP at 100µm reading).
 - maximum reading capacity varies with exposure level
- Slim and space-saving design that fits almost anywhere.
- No need for a darkroom with our imaging plates and cassettes.

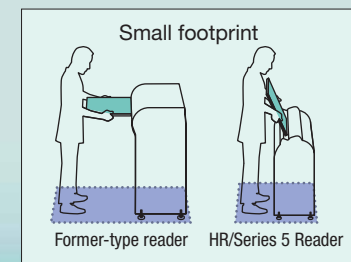

Review images on a high resolution monitor and store your image data registered with the image database on high-capacity removable media.

Image Display and File Management DynaView Workstation V5.0

- Easy processing of images. Magnify and measure as required. Measurement results can also be stored.
- Easy on the eyes without that flickering – the LCD screen gives clear images with high intensity and high contrast.
- Images registered with the image database are stored on removable media and can be quickly retrieved and displayed.
- Convert images into JPEG, BMP format for a variety of uses.
- Forget about layout space – the LCD monitor is flat and light.



Accessories

FUJIFILM IMAGING PLATE Industrial

Ultra-High Resolution Type
 (50 micron compatible)

UR-1 Packing Unit: 1 each
 Size
 • 35.4 x 43.0 cm (14" x 17")
 • 24 x 30 cm
 • 18 x 24 cm



Standard Resolution Type
 (100 micron compatible)

ST-VI Packing Unit: 1 each
 Size
 • 35.4 x 43.0 cm (14" x 17")
 • 25.2 x 30.3 cm (10" x 12")
 • 24 x 30 cm • 20.1 x 25.2 cm (8" x 10")
 • 18 x 24 cm • 15 x 30 cm



IP CASSETTE

Type UR Packing Unit: 1 each
 Size
 • 35.4 x 43.0 cm (14" x 17")
 • 24 x 30 cm
 • 18 x 24 cm



▲ Cassette adaptor for 24 x 30 cm

Type CC Packing Unit: 1 each

Size
 • 35.4 x 43.0 cm (14" x 17")
 • 25.2 x 30.3 cm (10" x 12")
 • 24 x 30 cm • 20.1 x 25.2 cm (8" x 10")
 • 18 x 24 cm • 15 x 30 cm

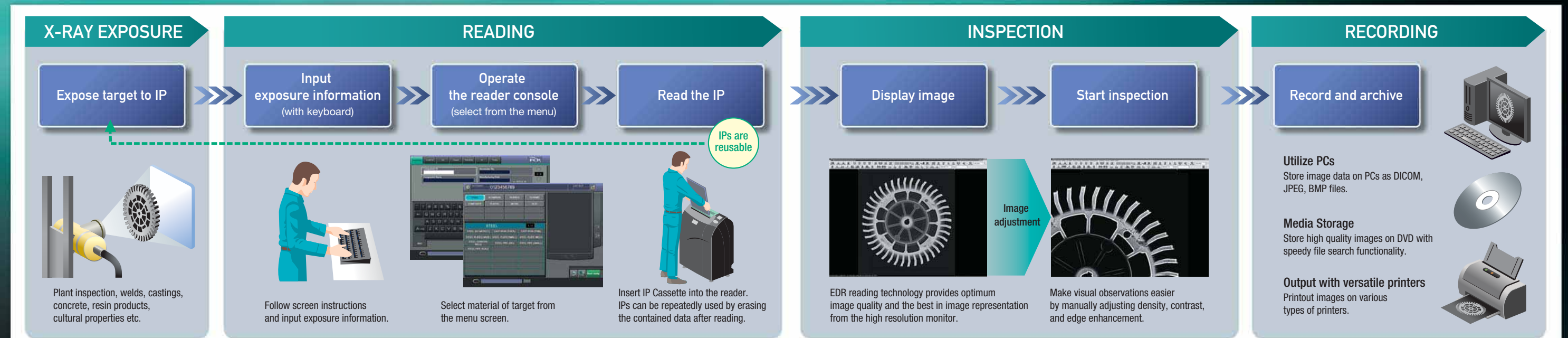

See what couldn't be seen with the X-ray inspection solution that expands capabilities.

Compared with time-consuming conventional analog film processing, the fully-digitalized FCR brings a highly technological and quick solution to the various needs of modern day X-ray inspection with its optimal high resolution images and environment friendly considerations.

➤ Issues Inherent to X-ray Inspection

Sample case 1 Aluminum Castings — Capturing automobile parts —

Radiograph inspection of castings with varying dimensions requires intricate X-ray voltage adjustment by each component part and also requires the separate capture of the various thick and thin proportions of the target by taking multiple exposure shots or by either using composite film — but that's with conventional X-ray film.

Sample case 2 High Density Circuit Boards — Magnification with the micro-focus device —

Particularly with conventional radiograph inspection, it takes more time than anticipated to inspect large targets due to minimal range capture with a single exposure and the inherent tendency of the surrounding areas being generally more unsharp than the central area.

Sample case 3 Plant Pipes — Take shots with the insulation material intact —

With plant facilities and piping, rail and road concrete structures — field inspection is the name of the game, requiring the immediate transportability of equipment and the capacity to readily inspect curved surfaces. In particular with pipe inspection, it has always been a work burden in stripping off and re-applying insulation materials and a cause of concern with the consequential negative effects to the human body and our environment.

Sample case 4 Aircraft Jet Engine Turbine Blades — Special alloy parts requiring high-accuracy inspection —

Even the slightest defect would be disastrous with turbines which are complexly designed for high heat resistance and high-efficiency, but there are defects that are difficult to discover with 100µm digital reading and obtaining finer image quality has been an issue.

Sample case 5 Image Transmission — Informed analysis and evaluation —

Both the inspection of product components under development and the inspection of products in the initial production phase require speedy analysis of the original images on an informed basis between responsible company departments, but they are in different locations.

FCR Solution 1 High resolution imaging of dimensional castings – and with a single shot.

IP does it all with its high resolution and wide dynamic range imaging, and with just one exposure shot. Edge portions are without halation, adding on to inspection accuracy and efficiency.

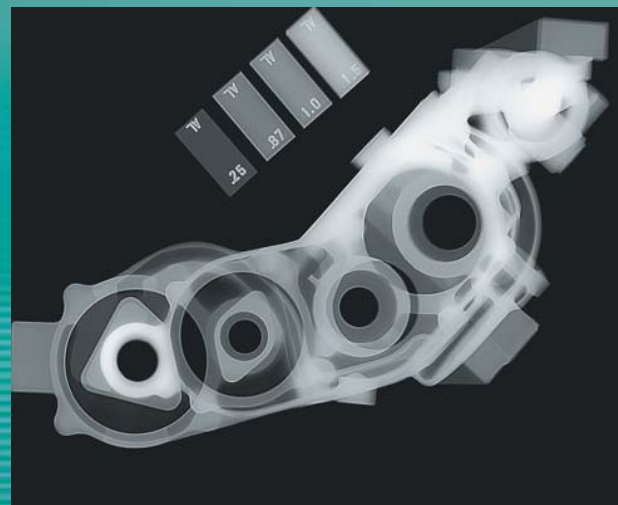

FCR Solution 2 A clear-cut corner to corner view of even large materials.

With FCR's laser reading technology, obtain a distinct image from corner to corner even using the largest IP size of 35.4 × 43.0 cm; making it possible to inspect large materials or large and highly complex electronic parts to the ultimate interior with fair ease.

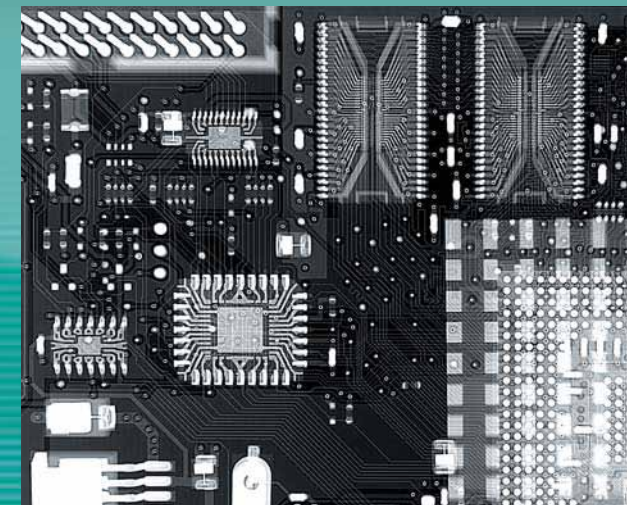

FCR Solution 3 Being light and bearing total flexibility, IP serves the best in onsite X-raying of pipes and without taking off that insulation material.

Being an X-ray detector with that needed flexibility and lightness, IP is the best match for the tough field whether it be in tight spots or high up; and it also reacts to gamma rays. Do radiograph inspections with the insulation material totally intact and be friendly to the environment and the human body.

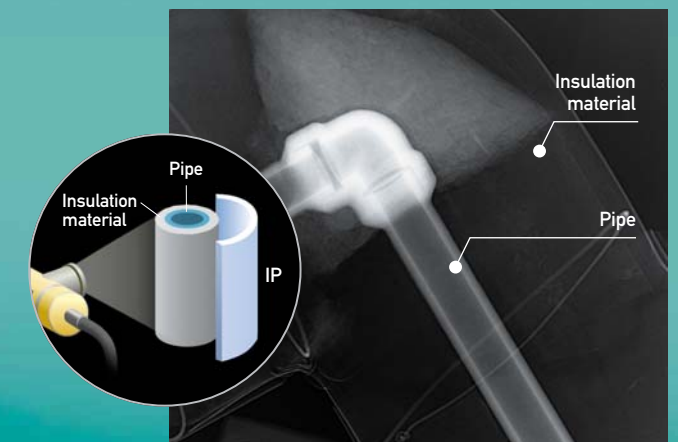

FCR Solution 4 High resolution reading and advanced image processing precisely capture even minute defects.

The FCR inspection scope has been expanded with high resolution of 50µm from our proprietary imaging processing engine which allows for enhanced visibility of precision parts requiring high inspection accuracy.

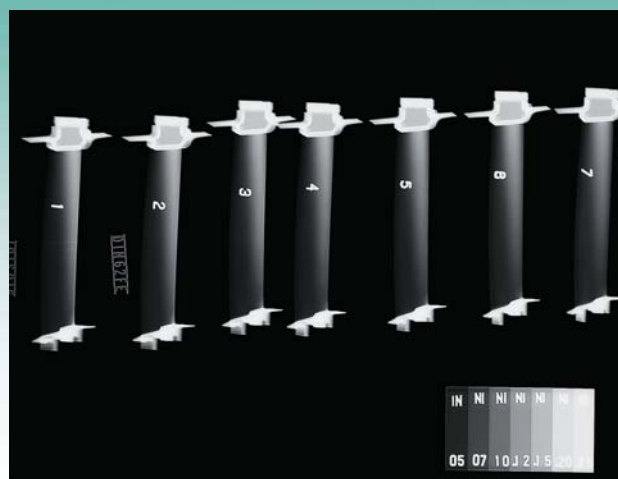

FCR Solution 5 Share image information between factories, research labs, and distant company locations.

FCR provides enhanced inspection accuracy through the sharing of informed analysis and evaluations even among distant company departments by transmitting images through the Internet.

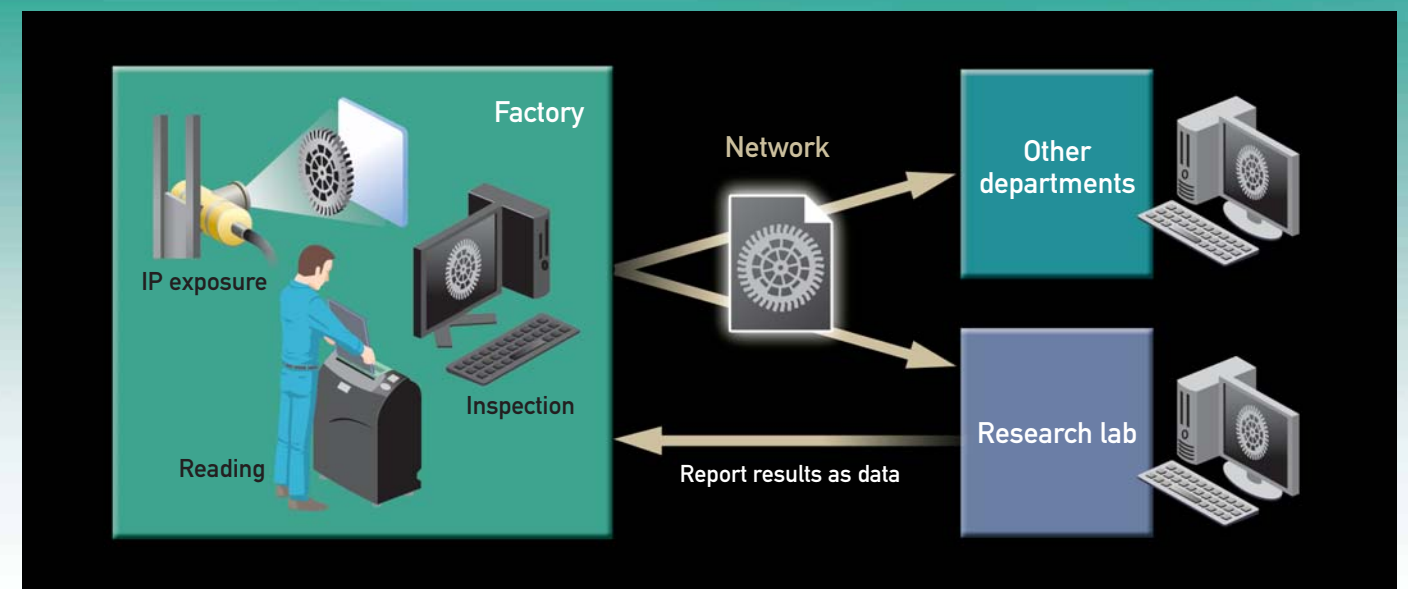

■ Dynamlx HR/Series 5 reader specifications

	Dynamlx HR		Dynamlx Series 5			
Compatible IP	ST-VI: 35.4 × 43.0 cm (14" × 17"), 25.2 × 30.3 cm (10" × 12"), 24 × 30 cm, 20.1 × 25.2 cm (8" × 10"), 18 × 24 cm, 15 × 30 cm UR-1: 35.4 × 43.0 cm (14" × 17"), 24 × 30 cm, 18 × 24 cm		ST-VI: 35.4 × 43.0 cm (14" × 17"), 25.2 × 30.3 cm (10" × 12"), 24 × 30 cm, 20.1 × 25.2 cm (8" × 10"), 18 × 24 cm, 15 × 30 cm			
Compatible IP cassette	Type CC: 35.4 × 43.0 cm (14" × 17"), 25.2 × 30.3 cm (10" × 12"), 24 × 30 cm, 20.1 × 25.2 cm (8" × 10"), 18 × 24 cm, 15 × 30 cm Type UR: 35.4 × 43.0 cm (14" × 17"), 24 × 30 cm*, 18 × 24 cm		Type CC: 35.4 × 43.0 cm (14" × 17"), 25.2 × 30.3 cm (10" × 12"), 24 × 30 cm, 20.1 × 25.2 cm (8" × 10"), 18 × 24 cm, 15 × 30 cm			
Reading resolution	UR-1	50µm				
	ST-VI	100µm	ST-VI	100µm		
Cycle time for IP feeding/loading	UR-1	35.4 × 43.0 cm (14" × 17")	Approx. 93 sec.			
		24 × 30 cm	Approx. 64 sec.			
		18 × 24 cm	Approx. 56 sec.			
	ST-VI	35.4 × 43.0 cm (14" × 17")	Approx. 58 sec.	ST-VI	35.4 × 43.0 cm (14" × 17")	Approx. 58 sec.
		25.2 × 30.3 cm (10" × 12")	Approx. 50 sec.		25.2 × 30.3 cm (10" × 12")	Approx. 50 sec.
		24 × 30 cm	Approx. 49 sec.		24 × 30 cm	Approx. 49 sec.
		20.1 × 25.2 cm (8" × 10")	Approx. 42 sec.		20.1 × 25.2 cm (8" × 10")	Approx. 42 sec.
		18 × 24 cm	Approx. 40 sec.		18 × 24 cm	Approx. 40 sec.
		15 × 30 cm	Approx. 49 sec.		15 × 30 cm	Approx. 49 sec.
	Reading gray scale	12 bits/pixel				
Dimensions (W × D × H)	590 × 380 × 810 mm					
Weight	99 kg					
Power supply	120/200-240VAC, 50-60HZ, 5A					
Operating conditions	15-30°C, 40-80%RH (No dew condensation)					

*24 × 30 cm Type UR cassette requires cassette adaptor when reading

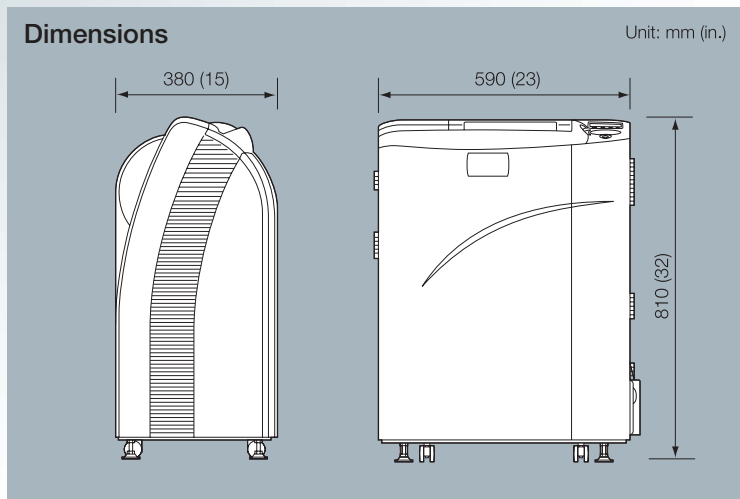

■ DynaView Workstation V5.0 functions

- (1) Automatic image enhancement (brightness, contrast, and edge-enhancement)
- (2) Manual brightness/contrast change
- (3) Magnification display of whole image
- (4) Magnification display of region of interest (ROI)
- (5) Measurement of length, angle, and SNR (ASTM Standard E2446-05 compliant)
- (7) Estimation of thickness
- (6) Input of annotation (text, arrows)
- (8) Import and export of images from/to removable media

<http://www.fujifilm.com/products/ndt>

